

# Battery-free Wireless Dome Button



CompuPhase  
Eerste Industriestraat 19  
1401VL Bussum, Netherlands



## Introduction

The “wireless Dome Button” is a large mushroom/ dome button that wirelessly transmits button presses to a workstation or PC, with the help of a “Wireless Dongle”.

The Wireless Dongle connects to a USB port. The workstation recognizes it as a “Human Interface Device” (HID), and specifically as a USB keyboard. Microsoft Windows, Linux and macOS have intrinsic support for HID. No drivers are necessary.

The key code that a button transmits to the PC is configured via a configuration utility (see the section “Configuring the Wireless Button”).

Up to six Wireless Buttons may be attached to a dongle. Each button is configured separately.

**The Battery-free Wireless Button requires a H0735 model dongle for reception.**

1

## First time use

Before the Wireless Button can be used, it must be attached to a Dongle. Please follow these steps:

1. Insert the Dongle in the PC.
2. Launch the “Key Configurator” utility. Download the Key Configurator from: <http://www.compuphase.com/usbkey/>
3. Verify that the utility detects the Dongle.
4. Press the Wireless Button once.
5. The utility scans for buttons. For a new Wireless Button, it pops up a dialog.
6. Enter the pin code for the Button. The pin-code is printed at the bottom of the Button.

The Wireless Button is now attached to the Dongle. You may proceed configuring the Button.

2

## Configuring the Wireless Button

The “Key Configurator” utility is available from <http://www.compuphase.com/usbkey/>.

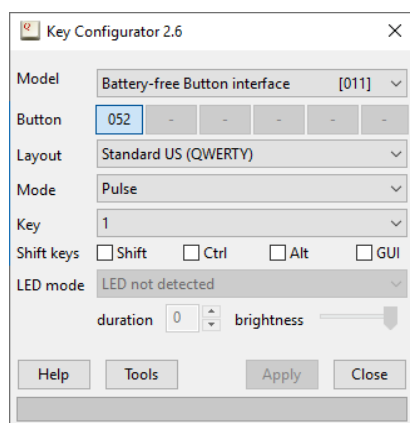

The utility configures only a single button at a time. The serial number, at the top right, shows which button is being configured.

3

You may need to press a Wireless Button before the Key Configurator detects and recognizes it.

If not using a US keyboard layout, please select the appropriate layout of the keyboard (QWERTY/AZERTY).

The mode can be “Pulse” or “Macro”. In *pulse* mode, the single key-code is transmitted; it does not repeat. In *macro* mode, you can specify a sequence of keys to be transmitted. For the syntax of macro mode, please see the Help function in the Key Configurator application.

After changing the configuration, you must click on Apply to store the settings in the USB button.

To test a Wireless Button, the Key Configurator must first be closed, so that the buttons toggle back from configuration mode to normal mode.

4

## Clear buttons / reset dongle

To reset a Wireless Dongle to factory defaults or to remove a Button from the Dongle, please see the Help function in the Key Configurator.

## Starting programs or commands

In Microsoft Windows, the **Windows** + R key combination shows the “Run” dialog. In “macro” mode, you can pop up this dialog with the key sequence “#R”. You can follow this by a command and then “{ENTER}” at the end to execute it. Other operating systems support similar functions, but may require a different key combination to pop up a “Run” dialog.

In addition, the Wireless Button supports several consumer control functions, like play, pause and others. These require pulse mode.

5

## Status LED

The LED indicator at the front side of the button briefly flashes at each *release* of the button. The LED does not flash when the button is pressed, but only at a release.

The flashing of the LED indicates that the energy harvesting circuit of the button is functioning properly. The energy harvesting circuit generates electric power on both a press and a release, but the power resulting from a press is used exclusively to transmit the key code to the dongle.

6

## Mounting the button

The base of the button has two mounting holes/slots for a permanent mount of the button on a table or a wall. See the arrows in the picture below for the location of these holes.

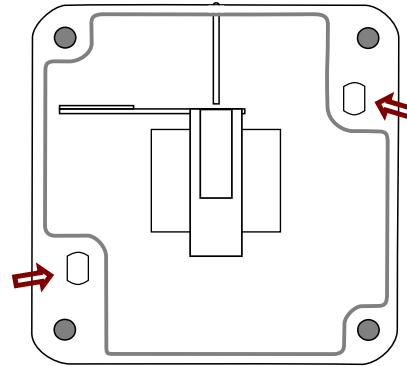

The mounting holes are suitable for 4 to 4.5 mm screws.

7

To get access to the two mounting holes in the base, the first step is to unscrew the top part of the button from the base

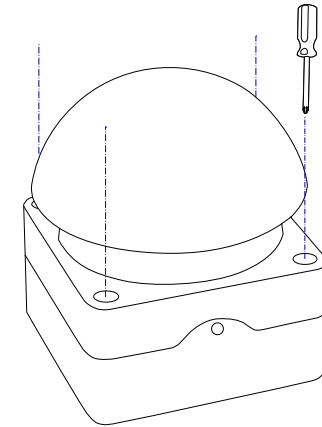

8

## Specifications

### Mechanical

Dimensions.....Base: 85×85 mm, height: 45 mm, dome diameter: 94 mm; total height: 101 mm;

Colour.....Base: black & grey; dome: red, black, green, yellow or white.

Mechanical lifespan.....> 10<sup>6</sup> operations.

Protection level.....IEC/EN 60529: IP65, IP67

Actuation force.....≤ 30 N.

### Operating conditions

Operating temperature...-25 °C to +40 °C.

Humidity.....5% to 95% non-condensing.

9

### Electronic interface

Power source.....Electro-mechanical energy harvesting generator; 0.25W of generated power per press

Switch latency.....30 ms maximum, 15 ms average.

Radio frequency.....868 MHz or 915 MHz, depending on model.

Transmission range.....> 30 meters outdoors (unobstructed line of sight).

### Conformity

Radio Equipment Directive (RED).....Compliant with EU Directive 2014/53/EU: ETSI EN 301 489-3:2002 V1.4.1, ETSI EN 300 220-2:2012 V2.4.1, ETSI EN 300 220-1:2012 V2.4.1

10

EMC.....Compliant with EU Directive 2014/30/EU: EN 55022 and EN 55024 + A1 (2001) + A2 (2003).

Electrical safety.....Compliant with EU Directive 2014/35/EU: EN 60950-1

RoHS.....Compliant with EU Directive 2011/65/EU: EN 50581:2012.

### Legal disclaimer

CompuPhase shall not be liable for the incidental or consequential losses or damage to tangible property, injury or death of a person in connection with the use of this device.

11